

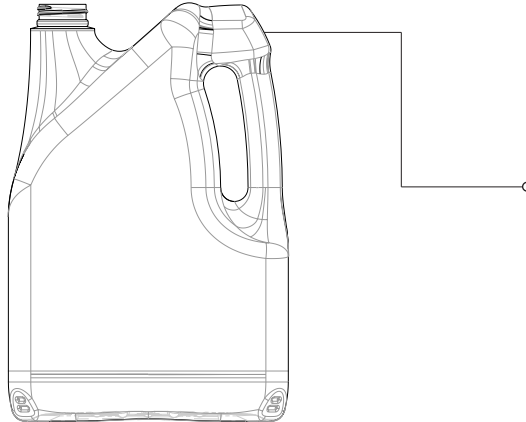

PLASTIC CONTAINERS

09.16.2020
5 Quart Old Style (160 oz) Bottle



- HDPE
- 163.2 oz. Capacity
- View Stripe: No
- 185 Grams
- Neck Finish: 38MM/SP-410
- Dimensions:
8.17Wx4.50Dx12.21H

Weight

- 198 lbs. per pallet

Pack-out

- 260 units per pallet
- 11,440 units/44 pallets per TL

Dimensions

Pallet Dims:
44.125Wx56.125Dx53.75H

Custom Colors

Available with minimum volume requirements

Stocked Colors

No stock colors available.

Labeling

Die line template available for pressure sensitive labels