

PRODUCT SPECIFICATION SHEET & PACK-OUT INFORMATION

ISO 9001:2015



PLASTIC CONTAINERS

Gallon (128 oz) Bottle

07.01.2020

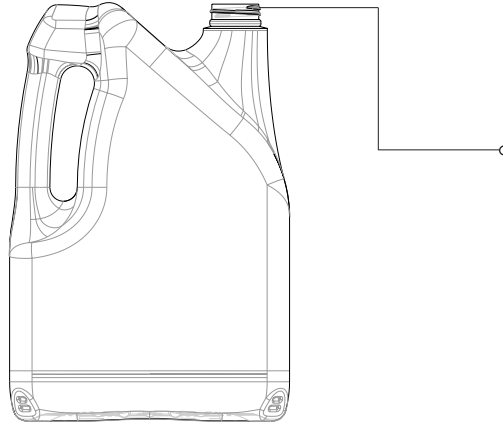

- HDPE
- 128 oz. Capacity
- View Stripe: No
- 165 Grams
- Neck Finish: 38MM SP410
- Dimensions:
8.17Wx4.50Dx10.94H

Weight

- 157 lbs. per pallet

Pack-out

- 260 units per pallet
- 11,440 units/44 pallets per TL

Dimensions

Pallet Dims:
44.75Wx56.125Dx53.5H

Custom Colors

Available with minimum volume requirements

Stocked Colors

- Black
- Orange
- Yellow
- White
- Silver
- Natural

Labeling

Die line template available for pressure sensitive labels