

PALLETIZED QUANTITIES:

Per Pallet: 2,574
Per Layer: 234

Layers Per Pallet: 11
Units TL: 56,628
Pallets TL: 22

BOTTLE DIMENSIONS:

4.266wX2.386dX8.500h

NECK FINISH:

1.220 28mm

PRODUCT SPECS:

Material: HDPE
Capacity: 32 oz.
View Stripe: Yes
Gram Weight: 52

FEATURE

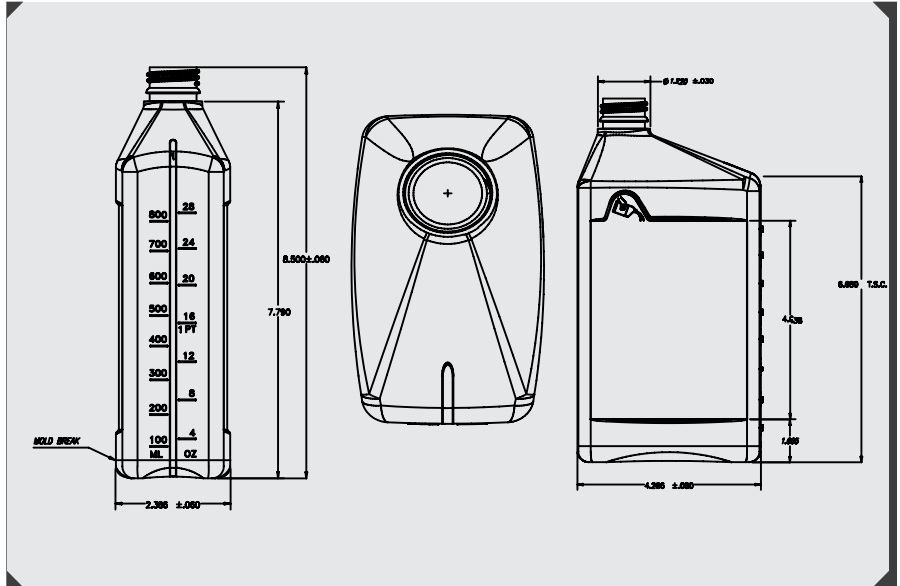

COLORS OPTIONS:



PALLET DIMENSIONS & WEIGHTS:

Pallet Dims: 56wX44dX96h
Wood: 425 lbs.
Plastic: 392-400 lbs.

LABELING:

Die Line Template Available
Pressure Sensitive Label

Custom colors available restrictions may apply

CUSTOMIZE IT!

CUSTOM COLORS AVAILABLE CONTACT US AT PLASTICCONTAINERS@MARTINLUBRICANTS.COM

Handling conditions vary a lot from customer to customer. Tests are recommended thought-out the process of denesting, filling, conveying palletization, warehousing, transportation and utilization by intermediaries and users. Specifications can change without notice. Please contact your Martin representative to confirm this data.

QMS QUALITY CONTROLLED PROCESS ISO CERTIFIED 4001971