

**PALLETIZED QUANTITIES:**

Per Pallet: 4,842  
Boxes Per Pallet: 9  
Per Box: 538

Units TL: 116,208  
Pallets: 24

**BOTTLE DIMENSIONS:**

5.053Hx2.750Wx1.734D

**NECK FINISH:**

28MM TE400

**PRODUCT SPECS:**

Material: HDPE  
Capacity: 8oz.  
View Stripe: No  
Gram Weight: 25

**FEATURE**

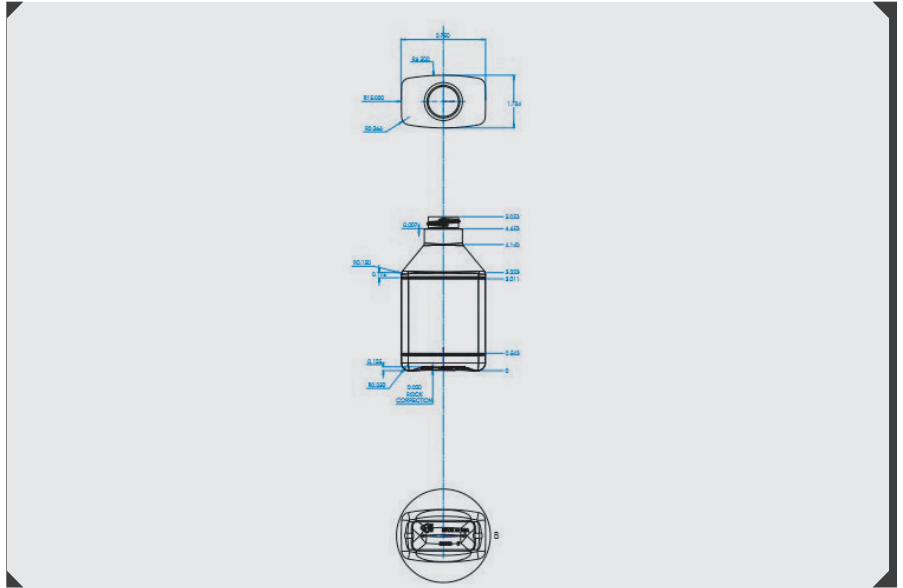

**COLORS OPTIONS:**



**PALLET DIMENSIONS & WEIGHTS:**

Pallet Dims: 50x36  
Pallet Height: 90"

**LABELING:**

Die Line Template Available  
Pressure Sensitive Label

**Stocked Colors: Black, White & Silver**

**CUSTOMIZE IT!**

**CUSTOM COLORS AVAILABLE CONTACT US AT [PLASTICCONTAINERS@MARTINLUBRICANTS.COM](mailto:PLASTICCONTAINERS@MARTINLUBRICANTS.COM)**

Handling conditions vary a lot from customer to customer. Tests are recommended thought-out the process of denesting, filling, conveying palletization, warehousing, transportation and utilization by intermediaries and users. Specifications can change without notice. Please contact your Martin representative to confirm this data.