



TECHNICAL DATA
Martin Plastics Division

2 GALLON BOTTLE (256oz.)

product specification sheet

REV: 03.27.2020

PALLETIZED QUANTITIES:

Per Pallet: 160
Per Layer: 40

Layers Per Pallet: 4
Units TL: 7,040
Pallets TL: 44

BOTTLE DIMENSIONS:

12.200H8.760W7.060D

NECK FINISH:

38MM/SP400

PRODUCT SPECS:

Material: HDPE
Capacity: 256 oz.
View Stripe: No
Gram Weight: 230

FEATURE

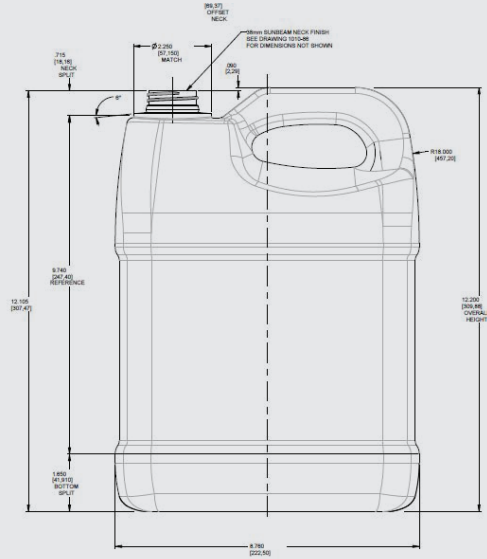

COLORS OPTIONS:



PALLET DIMENSIONS & WEIGHTS:

Pallet Dims: 44x56x58
Wood: 425 lbs.
Plastic: 392-400 lbs.

LABELING:

Die Line Template Available
Pressure Sensitive Label

Stocked Colors: Black, White, Orange, Yellow

CUSTOMIZE IT!

CUSTOM COLORS AVAILABLE CONTACT US AT PLASTICCONTAINERS@MARTINLUBRICANTS.COM

Handling conditions vary a lot from customer to customer. Tests are recommended thought-out the process of denesting, filling, conveying palletization, warehousing, transportation and utilization by intermediaries and users. Specifications can change without notice. Please contact your Martin representative to confirm this data.