



TECHNICAL DATA
Martin Plastics Division

2.5 GALLON (320oz.) - 38/400

product specification sheet

REV: 03.27.2020

PALLETIZED QUANTITIES:

Per Tray: 238
Per Layer: 34

Layers Per Pallet: 7
Units TL: 6,664
Trays: 28

BOTTLE DIMENSIONS:

8.849Wx14.250Hx11.39D

NECK FINISH:

38mm/SP400
Optional: M63 SP485 RELIABLE

PRODUCT SPECS:

Material: HDPE
Capacity: 2.6 oz
Gram Weight: 970 +/- 20g

FEATURE



Neck Finish:
63mm

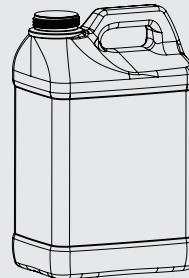

Optional:
38mm

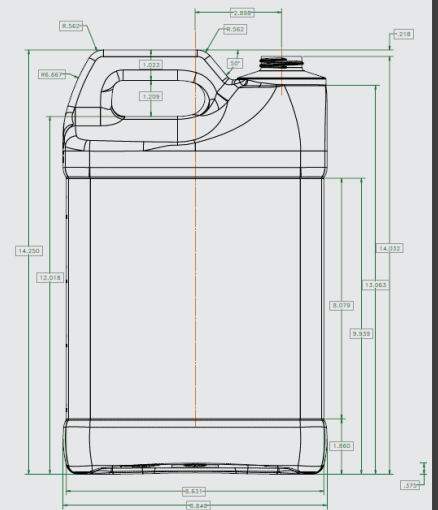
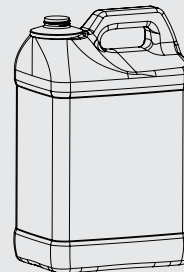

COLORS OPTIONS:



CORRUGATED TRAY DIMENSIONS:

49.75WX38DX99.75H

LABELING:

Die Line Template Available
Pressure Sensitive Label

Stocked Colors: White, Orange

CUSTOMIZE IT!

CUSTOM COLORS AVAILABLE CONTACT US AT PLASTICCONTAINERS@MARTINLUBRICANTS.COM

Handling conditions vary a lot from customer to customer. Tests are recommended thought-out the process of denesting, filling, conveying palletization, warehousing, transportation and utilization by intermediaries and users. Specifications can change without notice. Please contact your Martin representative to confirm this data.